

Ignition

The ignition system's function is to initiate combustion in the flammable air-fuel mixture by igniting it at precisely the right moment. In the spark-ignition (Otto) engine, this is achieved with an electrical spark, i.e. an arc discharge between the spark plug's electrodes. Consistently reliable ignition under all circumstances is essential for ensuring fault-free catalytic-converter operation. Misfiring results in damage to or destruction of the catalytic converter due to overheating during afterburning of the uncombusted mixture.

Mixture ignition

Provided the composition of the mixture is stoichiometric, energy of approximately 0.2 mJ is required for each individual ignition of the A/F mixture via electric spark. Over 3 mJ are required for a rich or lean mixture. This energy represents only a fraction of the total energy in the ignition spark, the actual ignition energy. If sufficient ignition energy is not available, there will be no ignition, the mixture cannot ignite, and misfiring will result.

The system must therefore deliver enough ignition energy to ensure consistently reliable ignition of the mixture, even under unfavourable conditions. Igniting a small flammable mixture cloud flowing past the spark can be enough to initiate the process. This mixture cloud ignites, the flame spreads to the remaining mixture in the cylinder, and the fuel starts to combust. Ignitability is enhanced by efficient fuel atomization and good access of the mixture to the electrodes, as well as through extended spark duration and spark length (large electrode gap).

The spark plug determines the location and length of the spark; spark duration depends upon the type and design of the ignition system, as well as on the momentary ignition conditions.

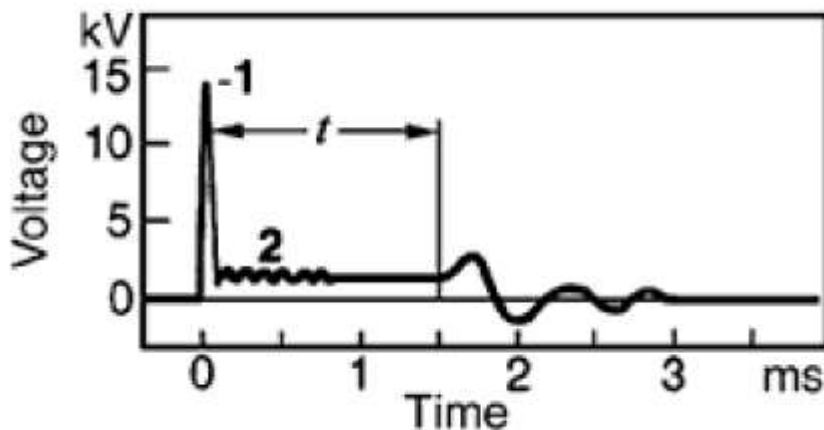

Spark-plug voltage characteristic with stationary or semi-stationary A/F mixture.

1 Ignition voltage, 2 Spark voltage, t Spark duration.

Spark generation

Adequate voltage must be present before a spark will arc from one electrode to another. At the moment of ignition, the voltage across the electrodes abruptly rises from zero

up to the arcing (ignition) voltage and the plug fires. Once the spark has ignited the spark-plug voltage drops to the sparking voltage. The A/F mixture may ignite at any point during the firing period of the ignition spark (spark duration). Once the spark has broken away, the voltage is damped and drops to zero.

Although intense mixture turbulence is basically desirable, it can extinguish the spark, thus leading to incomplete combustion. The energy stored in the ignition coil should therefore suffice for one or more consecutive sparks, depending on individual requirements.

High-voltage generation and energy storage

Battery-ignition systems generally employ an ignition coil to generate the high-tension voltage needed to generate the spark. The ignition coil operates as an autotransformer but within coil ignition systems it also assumes the further important function of storing the ignition energy. When the contact breaker closes, energy from the vehicle's electrical system flows into the coil's primary winding. This energy is then stored in a magnetic field until the firing point, when the secondary winding discharges it to one of the engine's spark plugs. The ignition coil is designed to ensure that the available high-tension voltage in the coil is always well in excess of the spark plug's maximum possible ignition-voltage requirement. Energy levels of 60...120 mJ within the coil correspond to an available voltage of 25...30 kV.

The operational reserves of high voltage and ignition energy are sufficient to compensate for all electrical losses. Inadequate maintenance reduces these high-voltage reserves, and leads to ignition and combustion miss. Engine power drops and fuel consumption increases. In addition, this phenomenon can result in damage to or destruction of the catalytic converter, should one be installed. In extreme cases, the engine either fails to start – especially when cold – or stalls.

Ignition systems are also available with capacitive energy storage (CDI or Capacitor Discharge Ignition) for use on high-performance and racing engines. These systems store the ignition energy in the electrical field of a capacitor before a special transformer transmits it to the spark plug in the form of a high-voltage ignition pulse.

Ignition timing and adjustment

Approximately two milliseconds elapse between the mixture's initial ignition and its complete combustion. The ignition spark must therefore arc early enough to ensure that main combustion, and thus the combustion-pressure peak in the cylinder, occur shortly after piston TDC. The ignition angle should therefore move further in the advance direction along with increasing engine speed. The chosen firing point should ensure that the following requirements are met:

- Maximum engine performance
- Low fuel consumption
- No engine knock
- Clean exhaust gas.

Since it is impossible to obtain optimal compliance with all of these requirements simultaneously; compromises must be found on a case-to-case basis. Optimal ignition timing is defined according to a variety of parameters. The most important are engine speed, engine load, engine design, fuel quality and momentary operating conditions (starting, idle and trailing throttle, etc.). In the simplest case, spark-advance mechanisms sensitive to variations in engine speed and intake-manifold vacuum adapt the ignition timing to suit the engine's current operating conditions.

In modern engine-management systems with extended functions, additional adjustments can be used e.g. for rapid torque adaptation or for swift heating of the catalytic converter. All the adjustment strategies can operate either individually or simultaneously. The

degree to which the ignition timing is advanced or retarded is determined by the ignition-advance curves calibrated specifically for each individual engine configuration.

At full load, the accelerator pedal is depressed fully and the throttle is wide open (WOT). Along with increasing engine speeds, ignition takes place earlier in order to maintain the combustion pressure at the levels required for optimal engine performance. The leaner A/F mixtures encountered during part-throttle operation are more difficult to ignite. Because this means that more time is required for ignition, it must be triggered earlier, with the timing being shifted further in the "advance" direction.

The manifold vacuum employed to determine the necessary degree of spark advance is monitored downstream from the throttle valve. If the vacuum bore is located near the throttle valve (see Ignition systems), the vacuum initially increases as the throttle is opened wider and begins to fall in the proximity of the full-throttle (WOT) position. The progressively wider throttle openings required to increase engine speed on the operating curve for part-throttle road operation are reflected in the relationship between vacuum and min^{-1} shown in the diagram.

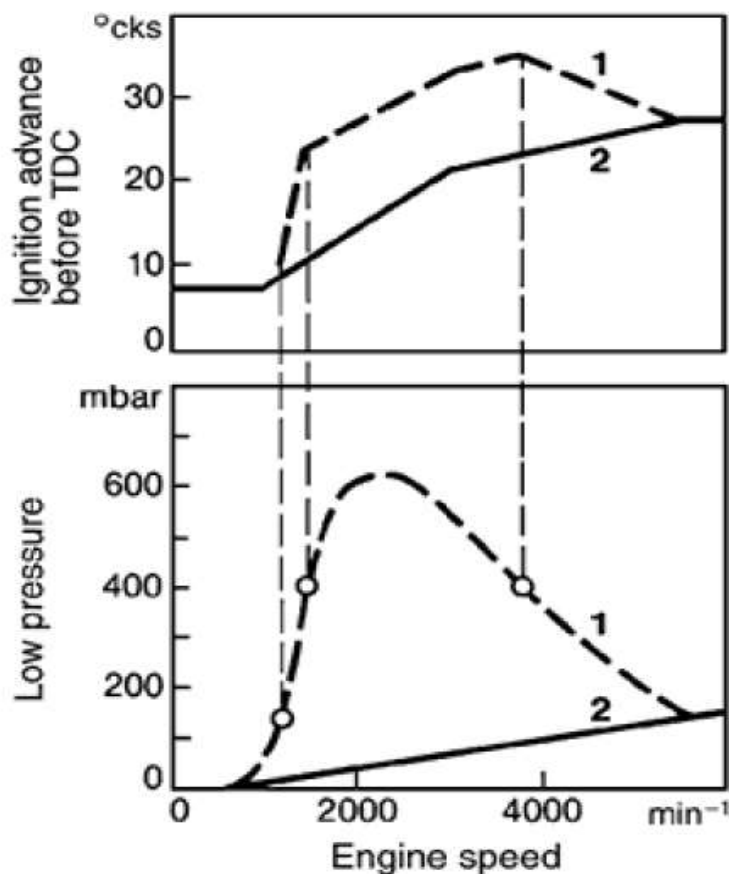

Example of cumulative ignition timing consisting of centrifugal and vacuum advance
 1 Part-load operation, 2 Full load.

Yet another diagram shows the curves for combustion-chamber pressure in a 4-stroke engine with correct and incorrect ignition timing. Even if the timing is initially correct, neglected maintenance can allow it to drift over the course of time. If the timing shifts towards a later firing point ("retard"), the result is a gradual drop in engine power and

increased fuel consumption. Excessive "advance" may result in extreme cases in serious damage to spark plugs or to the engine if the engine knocks. The level of exhaust emissions also increases.

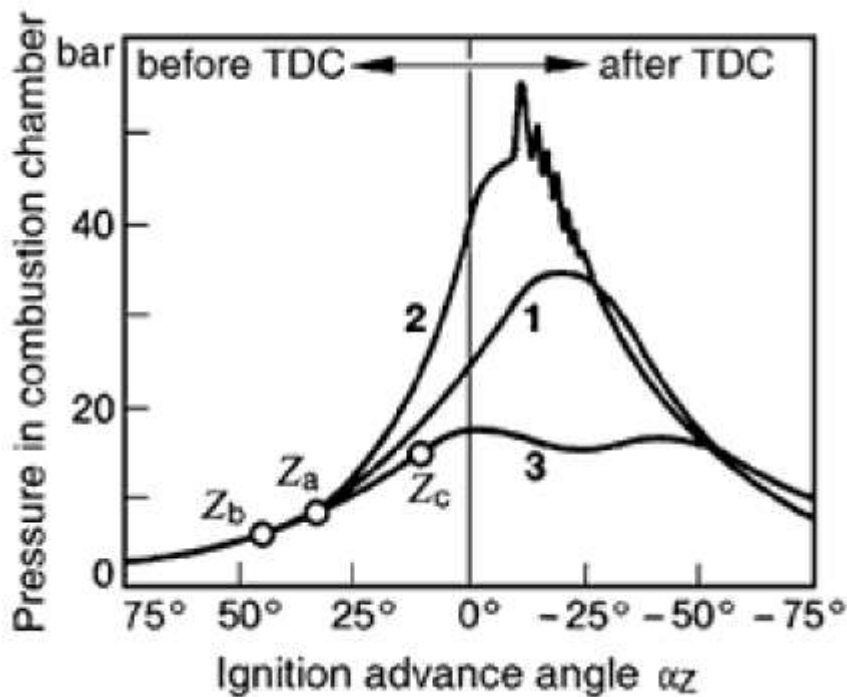

Combustion-pressure curve for various ignition firing points

- 1 Correct ignition advance (Z_a),
- 2 Excessive ignition advance (Z_b),
- 3 Excessive ignition retard (Z_c).

Ignition and emissions

Owing to the fact that it directly affects the various exhaust-gas components, the ignition has a significant effect upon exhaust emissions. Because various – and in this context sometimes mutually antagonistic – factors such as fuel economy, driveability, etc., are also potential optimization criteria, it is not always possible to specify the ideal ignition timing for minimum emissions.

Function	Ignition system		EII)	DLI
	CI	TI		
Designation	Coil ignition system	Transistorized ignition system	Electronic ignition system	Distributorless semiconductor ignition system
High-voltage generation	Inductive			
Ignition triggering	Mechanical	Electronic		
Ignition angle determined from engine speed and load	Mechanical		Electronic	
Spark distribution to appropriate cylinder	Mechanical			Electronic

1) Any desired ignition timing is not possible with EI. DLI therefore dominates with integrated engine-management systems.

Shifts in ignition timing induce mutually inverse response patterns in fuel consumption and exhaust emissions: While more spark advance increases power and reduces fuel consumption, it also raises HC and, in particular, NO_x emissions. Excessive spark advance can cause engine knock and lead to engine damage. Retarded ignition results in higher exhaust-gas temperatures, which can also harm the engine. Electronic engine-management systems featuring programmed ignition curves are designed to adapt ignition timing in response to variations in factors such as min-1, load, temperature, etc. They can thus be employed to achieve the optimum compromise between these mutually antagonistic objectives.

Ignition energy

The ignition system generates a high-voltage spark at the spark plug to initiate combustion. A ignition-spark energy of approx. 0.2 mJ is adequate to ignite a stoichiometric air-fuel mixture, while richer or leaner mixtures require substantially higher levels of spark energy. Excess energy, i.e., from an ignition system designed to generate a high-energy spark of extended duration (transistorized or electronic ignition) stabilizes flame propagation and reduces the fluctuations from cycle to cycle.

The reduction in fluctuations results in smoother engine operation and lower HC emissions. Increased spark projection, larger electrode gaps and thin electrodes also have a positive influence on the engine's smoothness and HC emissions.

Ignition coil

The ignition coil functions as both an energy-storage device and a transformer. The coil, which is powered by DC voltage from the vehicle's electrical system, supplies the ignition pulses for the spark plugs at the required high voltage and discharge energy. The ignition driver stage with its defined deactivation current combines with a primary winding featuring specific resistance and inductance characteristics to determine the amount of energy stored within the ignition coil's magnetic field. The secondary winding can be designed to provide peak voltage, spark current and discharge duration in accordance with individual requirements.

The contact-breaker points used with coil ignition (CI) can only handle interrupt currents of up to approx. 5 A. TI, EI and DLI ignition systems and Motronic ECUs can handle much higher interrupt currents. The series resistors generally employed with coil ignition (they can be bypassed to increase energy during cold starts) can be omitted in electronic ignition systems. Here the electronic circuitry activates the ignition coil depending on battery voltage, engine speed and other influencing variables in such good time that full energy is available at the ignition point.

Each ignition coil is designed to meet the requirements of a particular application. It must charge quickly in order to furnish the voltages and ignition energies required at high engine speeds. Important priorities thus include low primary inductance and, in some cases, higher primary interrupt currents (for adequate energy storage).

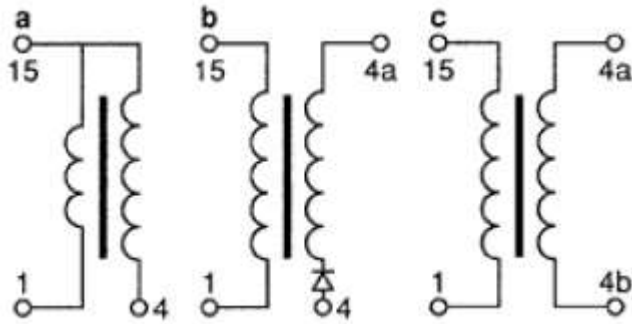

Ignition coils (schematic)

Rotating distribution: a) Single-spark ignition coil. **Distributorless ignition:** b) Single-spark ignition coil, c) Dual-spark ignition coil.

Design and operation

Traditional ignition coils with asphalt or oil insulation enclosed in metal casings are being increasingly replaced by units featuring an epoxy-resin filler. These not only allow more latitude in the selection of geometry, type and number of electrical terminals, but also provide more compact dimensions, better vibration resistance and lower weight. The ignition coil is generally attached by way of the iron core to the engine or vehicle body. Rod-type ignition coils are installed in the cylinder-head recess above the spark plug.

The coil's synthetic materials provide good adhesion between all of the high-voltage components and the molded epoxy resin, which penetrates into all the capillary spaces. Supplementary iron cores are sometimes embedded on the inside of the synthetic molding. The secondary winding is mostly designed as a disk or sandwich coil, with the windings distributed among a series of segments. Even distribution of stresses among the insulating elements in all chambers combines with high dielectric strength to permit compact dimensions while at the same time making foil and paper between wire layers redundant. The winding's self-capacitance is also reduced.

Because lower breakdown voltages are required for the negative (relative to engine ground) ignition spark, the positive terminals for the primary and secondary windings are generally combined on those ignition coils used with rotating high-voltage distribution. Single and dual-spark ignition coils are an alternative for use in ignition systems with distributorless ignition (DLI).

When a single-spark coil per spark plug is used, the primary current is controlled to furnish the relevant spark plug with an ignition pulse at precisely the right moment in time. High-voltage diodes are used to prevent the positive 1...2 kV high-voltage pulse generated when the primary current is activated from causing the spark plug to fire prematurely.

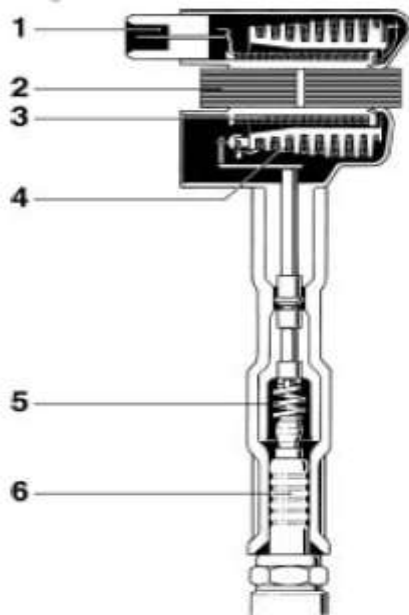

Single-spark ignition coil

1 External low-voltage terminal, 2 Laminated iron core, 3 Primary winding, 4 Secondary winding, 5 Internal high-voltage connection via spring contact, 6 Spark plug.

On the dual-spark coil, the secondary winding is galvanically insulated from the primary winding. Each of the two high-voltage outputs are connected to a spark plug. Ignition sparks are created at the two spark plugs when the primary current is deactivated. As with rotating high-voltage distribution, this system does not usually require any special precautions to prevent activation sparks.

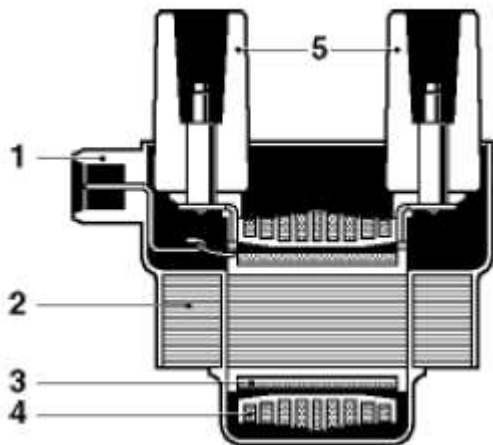

Dual-spark ignition coil (distributorless ignition)

1 Low-voltage terminal, 2 Laminated iron core, 3 Primary winding, 4 Secondary winding, 5 High voltage terminals.

Connection and installation are facilitated by combining several ignition coils in a common casing to form a single assembly. However, the individual coils continue to operate as independent units. The integration of output stages in the ignition coils means that short primary leads can be used (lower voltage drop). This arrangement also prevents power loss in the driver circuits from overheating the ECU.

Spark plug

Function

The spark plug introduces the ignition energy generated by the ignition coil into the combustion chamber. The high voltage creates an electric spark between the spark-plug electrodes which ignites the compressed A/F mixture. As this function must also be guaranteed under extreme conditions (cold starting, full load), the spark plug plays a decisive role in the optimum performance and reliable operation of a spark-ignition engine. These requirements remain the same over the entire service life of the spark plug.

Requirements

The spark plug must satisfy a variety of extreme performance demands: It is exposed to the varying periodic processes within the combustion chamber as well as external climatic conditions. However, the combustion chamber must remain sealed. During spark-plug operation with electronic ignition systems, ignition voltages of up to 30,000 V may occur and must not damage the insulator. This insulation capability must also be guaranteed at temperatures in the region of 1000 °C. Because the spark plug is subjected to mechanical stresses in the form of exposure to periodic pressure peaks (up to 80 bar) within the combustion chamber, its materials must exhibit extreme resistance to thermal loads and continuous vibratory stress. At the same time, that section of the spark plug that protrudes into the combustion chamber is exposed to high-temperature chemical processes, making resistance to aggressive combustion deposits essential. Because it is subjected to rapid variations between the heat of the combustion gases and the cool A/F mixture, the spark-plug insulator must feature high resistance to thermal stresses (thermal shock). Effective heat dissipation at the electrodes and the insulator is also essential for reliable spark-plug performance.

Design

In a special high-grade ceramic insulator, an electrically conductive glass seal forms the connection between the center electrode and terminal stud. This glass element acts as a mechanical support for the components while providing a gas seal against the high-pressure combustion gases. It can also incorporate resistor elements for interference suppression and burn-off.

The connection end of the insulator is glazed for improved protection against contamination. The connection between it and the nickel-plated steel shell is gas-tight. The ground electrode, like the center electrode, is primarily manufactured using nickel-based alloys to cope with the high thermal stresses. It is welded to the shell. The thermal conduction properties of both the center and the ground electrodes are improved by using a nickel-alloy jacket material and a copper core. Silver and platinum, or platinum alloys, are employed as electrode material for special applications. The spark plugs have either an M4 or a standard SAE thread, depending upon the type of high-voltage connection. Spark plugs with metal shields are available for watertight systems and for maximum interference suppression.

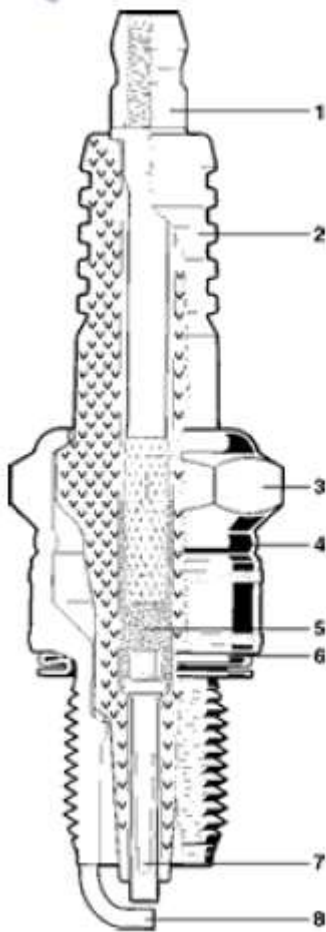

Spark plug

- 1 High-voltage connector (terminal nut),
- 2 Al₂O₃ Ceramic insulator,
- 3 Shell,
- 4 Heat-shrinkage zone,
- 5 Conductive glass,
- 6 Captive gasket,
- 7 Composite center electrode Ni/Cu,
- 8 Ground electrode.

Ignition systems

Conventional coil ignition (CI)

Many vehicles are still equipped with conventional coil ignition. When the contact breaker closes with the ignition switched on, current from the battery or alternator flows through the ignition coil's primary winding, generating a powerful magnetic field in which the energy is stored. At the ignition point, the contact breaker interrupts the current, the magnetic field collapses and the high voltage necessary for ignition is induced in the secondary winding. This voltage is fed from terminal 4 to the ignition distributor via a high-tension cable and from there to the individual spark plugs.

The following is a basic definition of the relationship between the speed of a four-stroke SI engine and the number of sparks generated per minute:

$$f = z \cdot n/2$$

f is Spark-generation rate, z is Number of cylinders, n is Engine speed.

At low engine speeds, the contact-breaker points remain closed long enough to exploit the coil's full energy-storage potential. At higher engine speeds, this contact period – the dwell angle – is shorter, and the primary current is interrupted before maximum energy can be transferred to the coil. The resulting reduction in stored energy means that less high-tension current is then available from the coil.

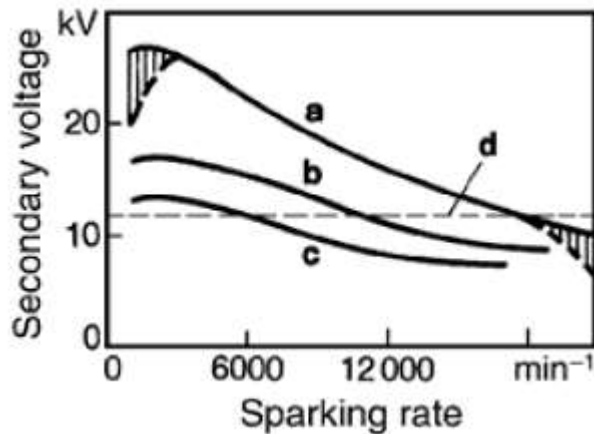

Secondary voltage as a function of sparking rate

- a Without ohmic shunts ($R > 10 \text{ M}\Omega$),
- b Shunt resistance $1 \text{ M}\Omega$,
- c Shunt resistance $0,5 \text{ M}\Omega$,
- d Required ignition voltage.

In response, ignition coils are designed to provide high-tension voltage well in excess of the spark plugs' requirements, even at maximum engine speeds. Contamination on the insulating components acts as a capacitive and ohmic shunt, increasing the ignition loads placed upon the system, with combustion and ignition misfiring as the ultimate consequences.

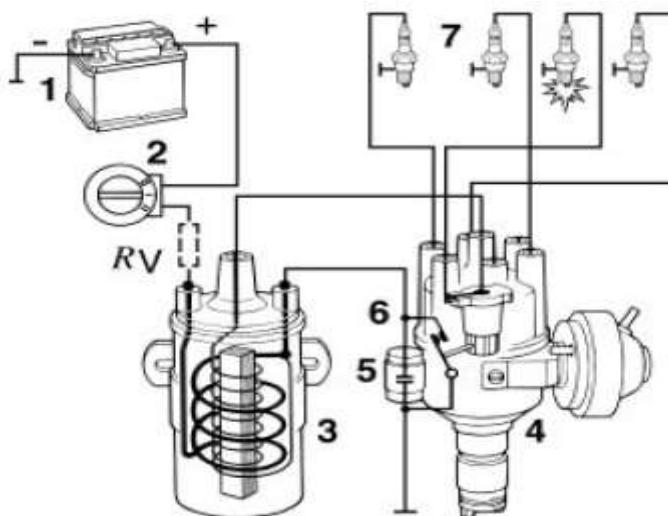

Conventional coil-ignition system (CI), components

- 1 Battery, 2 Ignition switch, 3 Coil, 4 Distributor, 5 Ignition condenser, 6 Contact breaker, 7 Spark plugs. Rv Ballast resistor for increased start voltage (optional).

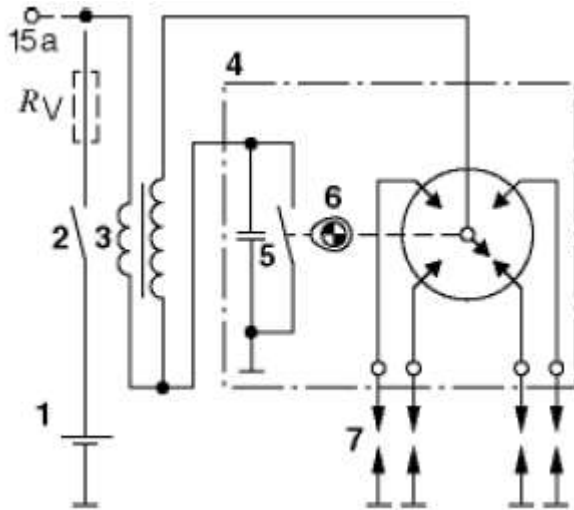

Conventional coil-ignition system (CI), circuit diagram

1 Battery, 2 Ignition switch, 3 Coil, 4 Distributor, 5 Ignition condenser, 6 Contact breaker, 7 Spark plugs.

Rv Ballast resistor for increased start voltage (optional).

Ignition distributor

The distributor is a separate, self-contained component within the ignition system. It has the following functions:

- it distributes the ignition pulses to the engine's spark plugs in the defined sequence (CI, TI, and electronic ignition).
- triggers the ignition pulse, either when the contact breaker interrupts the primary current, or, with breakerless systems (CI, TI, EI in some cases), using a pulse generator.
- adjusts the ignition timing with a spark-advance mechanism on conventional ignition systems (CI, TI).

In modern electronic ignition systems, operating either alone or in combination with the fuel injection system (Motronic), the distributor generally comprises only a rotor arm connected to the camshaft and the distributor cap with high-voltage cables. The contact-breaker points and the spark-advance mechanism perform separate functions from those of the distributor proper. They are combined with it in a single unit because they require a synchronized drive. The ignition pulse passes through the center connection and the carbon brush or the center-tower spark gap to the distributor's rotor arm which then distributes this ignition energy by arcing it to fixed electrodes pressed into the periphery of the distributor cap. From here, the ignition pulses travel through the ignition cables to the spark plugs. A dust cover is sometimes installed to separate this high-voltage section from the rest of the unit.

Contact breaker

A cam opens the contact-breaker points to interrupt the flow of primary current to the coil for ignition. The number of cam lobes corresponds to the number of engine cylinders. The portion of the distributor shaft's rotation during which the points remain closed is the dwell angle.

The contact-breaker points are subject to three types of wear:

- contact pitting,
- contact arm (rubbing-block) wear,
- plastic deformation and local compression of the contact metal.

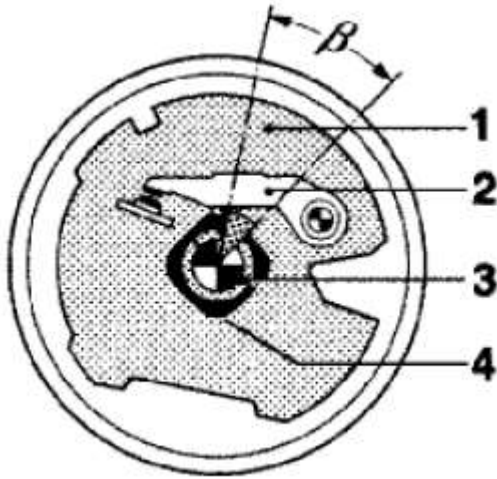

Contact breaker

1 Moving breaker-plate assembly, 2 Breaker lever, 3 Distributor shaft, 4 Distributor cam.

Contact pitting stems from the breaking sparks (residual arcing) induced by induction voltage during interruption of the primary current. The ignition condenser is designed to suppress this type of arcing, but residual sparks continue to occur. Although contact wear and rubbing-block wear are mutually counteractive, the effects of the latter are generally more pronounced, resulting in a tendency for the ignition to drift in the "retard" direction, toward a later ignition point.

Spark-advance mechanism

Ignition distributors are generally equipped with two spark-advance mechanisms: a speed-sensitive centrifugal advance mechanism and a load-dependent vacuum-controlled device.

Centrifugal advance mechanism

The centrifugal advance mechanism adjusts the ignition timing in response to changes in engine speed. The support plate upon which the flyweights are mounted rotates with the distributor shaft.

The flyweights move outward as engine speed increases, thereby turning the driver over the contact path to the distributor shaft in the direction of rotation. In this way, the distributor cam also turns towards the distributor shaft by the ignition advance angle α . The point of ignition is advanced by this angle.

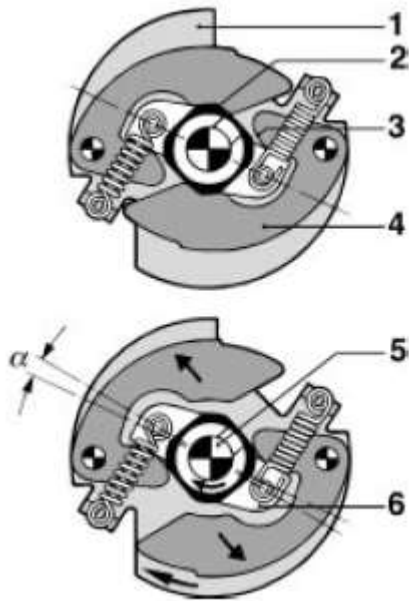

Centrifugal advance mechanism, at rest (above), in operation (below)

1 Support plate, 2 Distributor cam, 3 Contact path, 4 Advance flyweight, 5 Distributor shaft, 6 Driver.

Vacuum adjustment mechanism

The vacuum mechanism adapts the ignition timing to changes in engine output and load factor. Intake manifold vacuum is monitored or tapped off in the vicinity of the throttle valve. The vacuum acts upon two aneroid capsules.

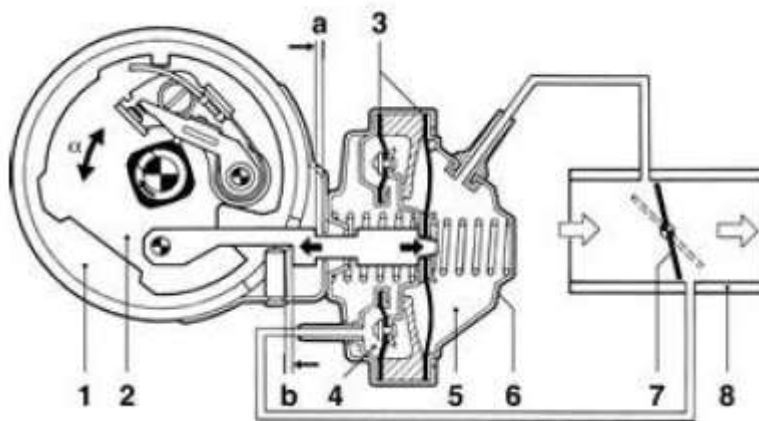

Vacuum advance mechanism with ignition advance and retard units

a Advance adjustment up to stop,

b Retard adjustment up to stop

1 Ignition distributor, 2 Breaker-plate assembly, 3 Diaphragm, 4 Vacuum retard unit, 5 Vacuum advance unit, 6 Vacuum unit, 7 Throttle valve, 8 Intake manifold.

Operation of advance mechanism

Because the air/fuel mixture combusts more slowly during operation at low load factors, it must be ignited earlier to compensate. Meanwhile, the proportion of those residual

gases which have been burned but not discharged from the combustion chamber increases, and the mixture leans out.

Vacuum for the advance mechanism is tapped off immediately downstream from the open throttle valve. As the engine load decreases, the vacuum in the advance unit rises, causing the diaphragm and its control arm to move to the right. The control arm turns the breaker-plate assembly against the distributor shaft's direction of rotation; the point of ignition is advanced still further.

Operation of retard mechanism

Here the connection with the intake manifold's internal vacuum is downstream from the closed throttle. The ring-shaped vacuum retard unit reduces exhaust emissions by reducing ignition advance under specific operating conditions (e.g. idle, trailing throttle). The ring diaphragm and its control arm move to the left when vacuum is applied. The control arm rotates the breaker-plate assembly together with the contact breaker in the distributor shaft's direction of rotation.

This spark-retard system operates independently of the advance mechanism. The advance mechanism has priority: simultaneous vacuum in both units during part-throttle operation shifts the unit to its "advance" position.

Transistorized ignition (TI)

With conventional coil-ignition systems, ignition energy and maximum voltage are restricted by various electrical and mechanical factors limiting the breaker points' switching capacity. The demands placed upon battery-ignition systems are often more than the contact-breaker assembly can satisfy in its role as a power switch. In electronic ignition systems, the points are assisted or replaced entirely by wear-free control devices. Transistorized (coil) ignition is available in both breaker triggered and breakerless versions.

Transistorized coil ignition with contact control is especially suitable for upgrading existing coil ignition systems (CI). Breaker-triggered transistorized coil ignition systems are no longer installed as original equipment.

Breakerless transistorized ignition

On breakerless transistorized ignition systems, the cam-actuated contact breaker is replaced by a magnetic "pulse generator". This generates current and voltage pulses magnetically (without contacts) to trigger the high-voltage ignition pulse through the system electronics. The pulse generator is installed in the ignition distributor.

These triggering devices operate according to various principles.

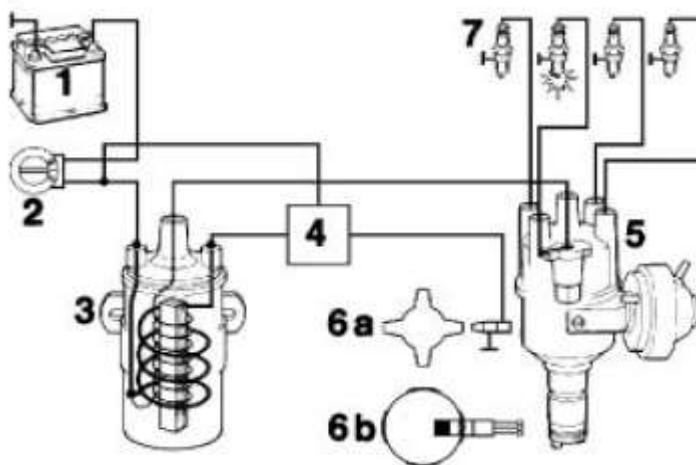

Breakerless transistorized ignition system

1 Battery, 2 Ignition switch, 3 Coil, 4 Electronic trigger box, 5 Ignition distributor with centrifugal and vacuum advance mechanism, 6a Induction-type pulse generator, 6b Hall-type pulse generator (alternative), 7 Spark plugs.

Induction-type pulse generators (TI-I)

The induction-type pulse generator is a permanently-excited AC generator consisting of stator and rotor. The number of teeth or arms corresponds to the number of cylinders in the engine. The frequency and amplitude of the alternating current generated by the unit vary according to engine speed. The ECU processes this AC voltage and uses it for ignition control.

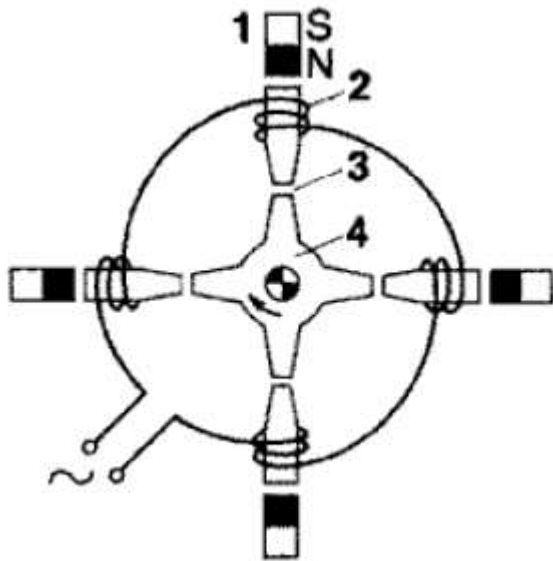

Ignition distributor with induction-type pulse generator

1 Permanent magnet, 2 Induction winding with core, 3 Variable air gap, 4 Trigger wheel.

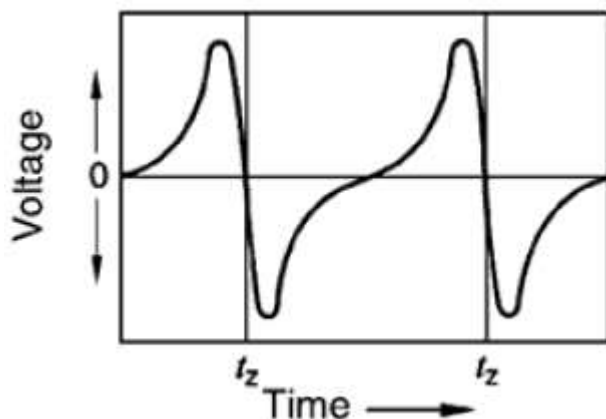

Ignition distributor with induction-type pulse generator

Hall-effect pulse generators (TI-H)

This type of ignition-pulse generator utilizes the Hall effect. A speed-sensitive magnetic field produces voltage pulses in an electrically charged semiconductor layer to control activation of the ECU's primary current.

Ignition pulse generators (impulsers) display clear benefits over mechanical contact breakers: They do not wear, and are thus maintenance-free. They allow precise control of ignition timing with attendant benefits in engine performance.

Electronic control units

Virtually all of the electronic control units (trigger boxes) in use today are equipped with primary current regulators and closed-loop dwell-angle control.

The primary-current regulator limits the current in order to protect the ignition coil and the driver stage. When used in conjunction with a coil featuring low primary resistance, it provides high starting current at low battery voltages. This makes it possible to dispense with series resistors upstream of the coil as well as with the bridging function for starting. Closed-loop dwell-angle control ensures that the desired primary current is obtained in the control range as far as possible at the point of ignition. This reduces the power losses in the ECU. It also compensates for battery-voltage fluctuations and ignition-coil temperature effects. Depending on system design, this dwell-angle control is effective up to medium engine speeds. At high engine speeds, the dwell angle is determined by the break time required to achieve adequate arcing durations. The residual energy remaining in the coil after the break time promotes optimal coil charging with reduced dwell times.

The sparkless closed-circuit current deactivation switches off the primary current with the ignition on and the engine off to ensure that no sparks occur at the spark plug. However, there are also TC-I systems (with induction-type pulse-generator) with intrinsic closed-circuit current deactivation.

Transistorized ignition is sometimes employed together with auxiliary devices to adjust the spark advance. An example would be the idle-speed control which is installed between the Hall generator and the ECU; below idle speed it reacts to further decreases in engine min^{-1} by advancing the ignition, thus increasing torque and preventing engine speed from dropping any further. The electronic retard device reduces ignition advance at high engine speeds to prevent knocking. It is connected in parallel with the ECU. Today, both of these functions are integrated in the electronically adjusted ignition systems within the engine-management system.

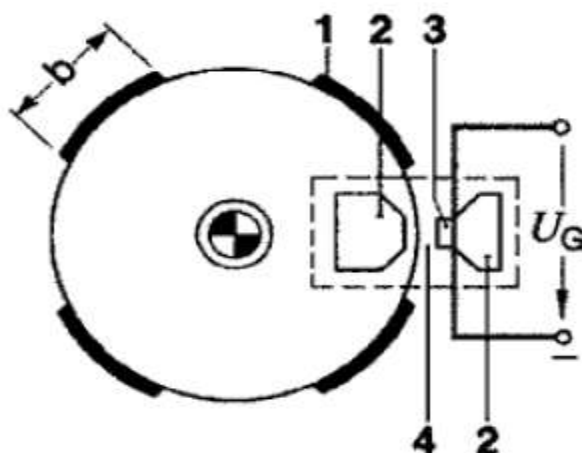

Ignition distributor with Hall sensor

1 Vane with width b , 2 Soft-magnetic conductive elements, 3 Hall IC, 4 Air gap, UG Sensor voltage (transformed Hall voltage).

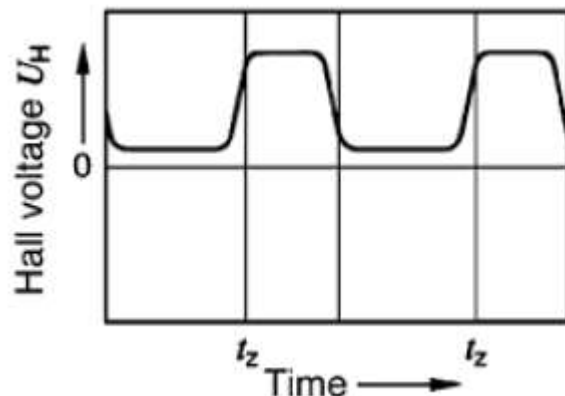

Ignition distributor with Hall sensor

Hybrid units have become the ECU standard for transistorized ignition systems owing to their ability to combine high packaging density with low weight and excellent reliability. Hybrid technology replaces the printed-circuit board, with an Al_2O_3 substrate bearing conductor paths and resistors applied in a silk-screening process. Semiconductor devices and capacitors in chip form complete the circuit. As the Darlington power-transistor chip is mounted insulated on the metallic base plate, cooling is excellent, permitting operation at high temperatures.

Ignition coils

The performance specifications of ignition coils for conventional ignition differ from those of ignition coils with electronic circuit-breakers (see Transistorized ignition). A coil designed for one application should never be employed in the other.

Note: Unlike with breaker-triggered ignition, terminal 1 of the systems mentioned must not be shorted to ground (e.g. during compression testing) as this would overload the low-resistance primary winding of the ignition coil.

Capacitor-discharge ignition (CDI)

The operating concept behind CDI, or "thyristor ignition", as it is also called, differs from that of the ignition systems described above. CDI was developed for use with high-speed, high-output multi-cylinder reciprocating IC engines in high-performance and competition applications and for rotary piston engines.

The salient characteristic of the CDI system is that it stores ignition energy in the electrical field of a capacitor. Capacitance and charge voltage of the capacitor determine the amount of energy which is stored. The ignition transformer converts the primary voltage discharged from the capacitor to the required high voltage. Capacitor-discharge ignition is available in both breaker-triggered and breakerless versions.

The major advantage of the CDI is that it generally remains impervious to electrical shunts in the high-voltage ignition circuit, especially those stemming from spark-plug contamination. For many applications, the spark duration of 0.1...0.3 ms is too brief to ensure that the air-fuel mixture will ignite reliably. Thus CDI is only designed for specific types of engine, and today its use is restricted to a limited application range, as transistorized ignition systems now afford virtually the same performance. CDI is not suited for aftermarket installations.

CDI can also be employed for distributorless ignition (DLI) with the installation of one ignition coil per cylinder, with energy distribution taking place at the medium-voltage level.

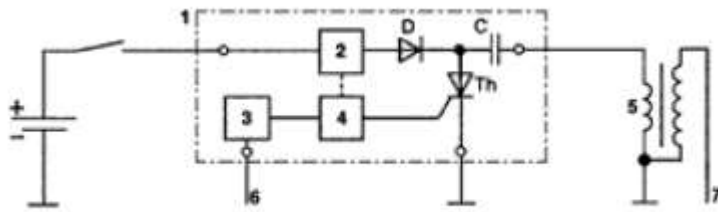

Capacitor-discharge ignition system with induction-type pulse generator, schematic

1 Control unit, 2 Charger, 3 Pulse shaper, 4 Control stage, 5 Ignition transformer, 6 To induction type pulse generator, 7 To ignition distributor.

Electronic ignition (EI and DLI)

Electronic ignition derives its name from the fact that it calculates the ignition point electronically.

The characteristic curves provided by the conventional distributor's centrifugal and vacuum-advance units are replaced by an optimized electronic ignition map. Mechanical high-tension distribution is retained with EI ignition. Fully electronic distributorless semiconductor ignition (DLI) uses stationary electronically controlled components to replace the mechanical, rotating high-tension distributor.

Electronic ignition systems operate more precisely than mechanical systems, with major benefits originating in the fact that the ignition process can be triggered from the crankshaft instead of from a distributor (distributor drive tolerances are no longer a factor). The limitations which mechanical adjustment mechanisms place upon the performance curve (summation of curves for load and engine speed in a single progression) are also avoided. The number of input variables is also theoretically unlimited, usually allowing extensions in the ignition angle's adjustment range. The fixed-drive ignition distributor's limitations regarding the engine's ignition-voltage requirements and ignition angle adjustment range are such that it has difficulty coping with larger numbers of cylinders; efficient spark distribution cannot always be guaranteed. Corrective measures include dividing the ignition into two circuits (e.g., for 8- and 12-cylinder engines) and static voltage distribution.

Electronic ignition can be combined with electronic fuel-injection (Motronic), knock control, ASR, etc., making it possible to employ sensors and/or signals from other units in more than one system. A serial bus (see CAN) further reduces the number of inputs and processing circuits on the ECU's input-side.

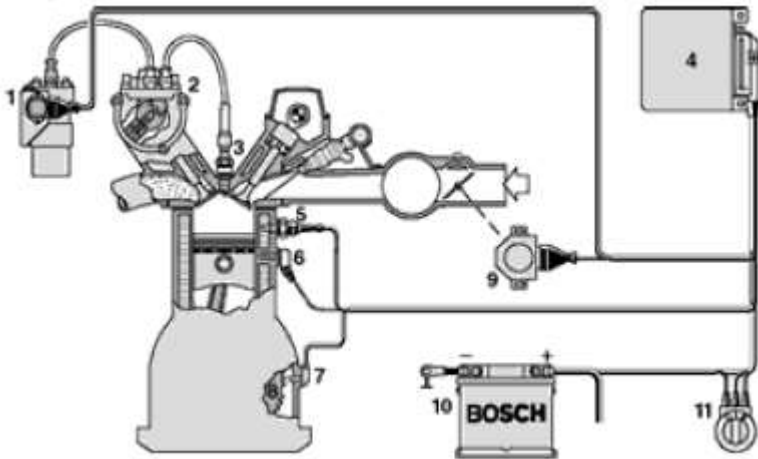

Schematic of an electronic ignition system (EI)

1 Ignition coil with ignition driver stage, 2 High-voltage distributor, 3 Spark plug, 4 ECU, 5 Engine temperature sensor, 6 Knock sensor, 7 Engine-speed and reference-mark sensor, 8 Ring gear for sensor, 9 Throttle switch, 10 Battery, 11 Ignition switch.

Operation

The engine's speed and crankshaft position are monitored directly at the ring gear, using either a separate rotor or a specific pin sequence employing an inductive, rod-type sensor, with two sensors being employed on older units. Triggering is either incremental or segmentary, according to whether the information is taken from teeth distributed evenly around the crankshaft or a crankshaft segment per cylinder pair:

- Beginning of segment = maximum spark advance angle,

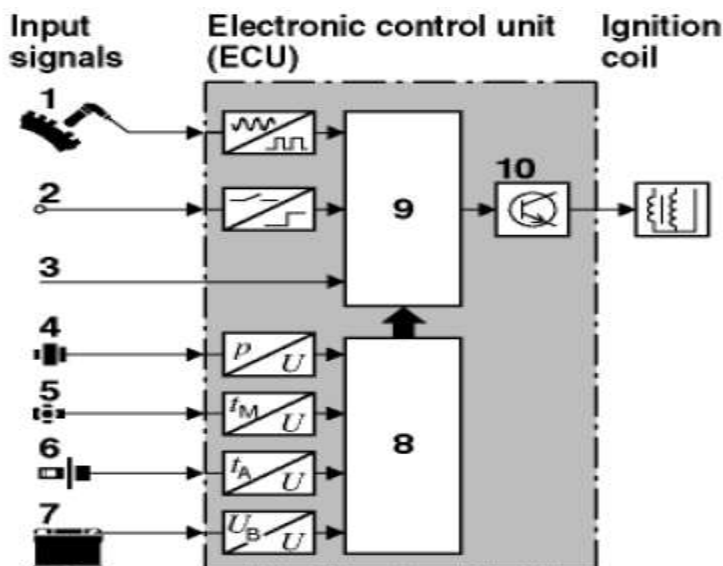

Electronic ignition, signal processing

1 Engine speed, 2 Switch signals, 3 CAN (serial bus), 4 Intake-manifold pressure, 5 Engine temperature, 6 Intake-air temperature, 7 Battery voltage, 8 Microprocessor, 9 Analog/digital converter, 10 Driver stage.